

# MALLET KEYBOARD HOLDER ASSEMBLY INSTRUCTIONS

SEE VIEW I

1. Attach fixed rest to body tubing and tighten securely.
2. Determine length of instrument and attach adjustable rest so as the attachment bolt will be positioned approx. midway in the slot of the adjustable rest.
3. Attach the two mounting clamps to the percussion rack tubing in desired location.
4. Attach the Mallet Keyboard Holder to rack clamps. Adjust height as required.
5. Install Mallet Keyboard Holder by sliding adjustable clamp tightly against instrument and tighten knob securely.

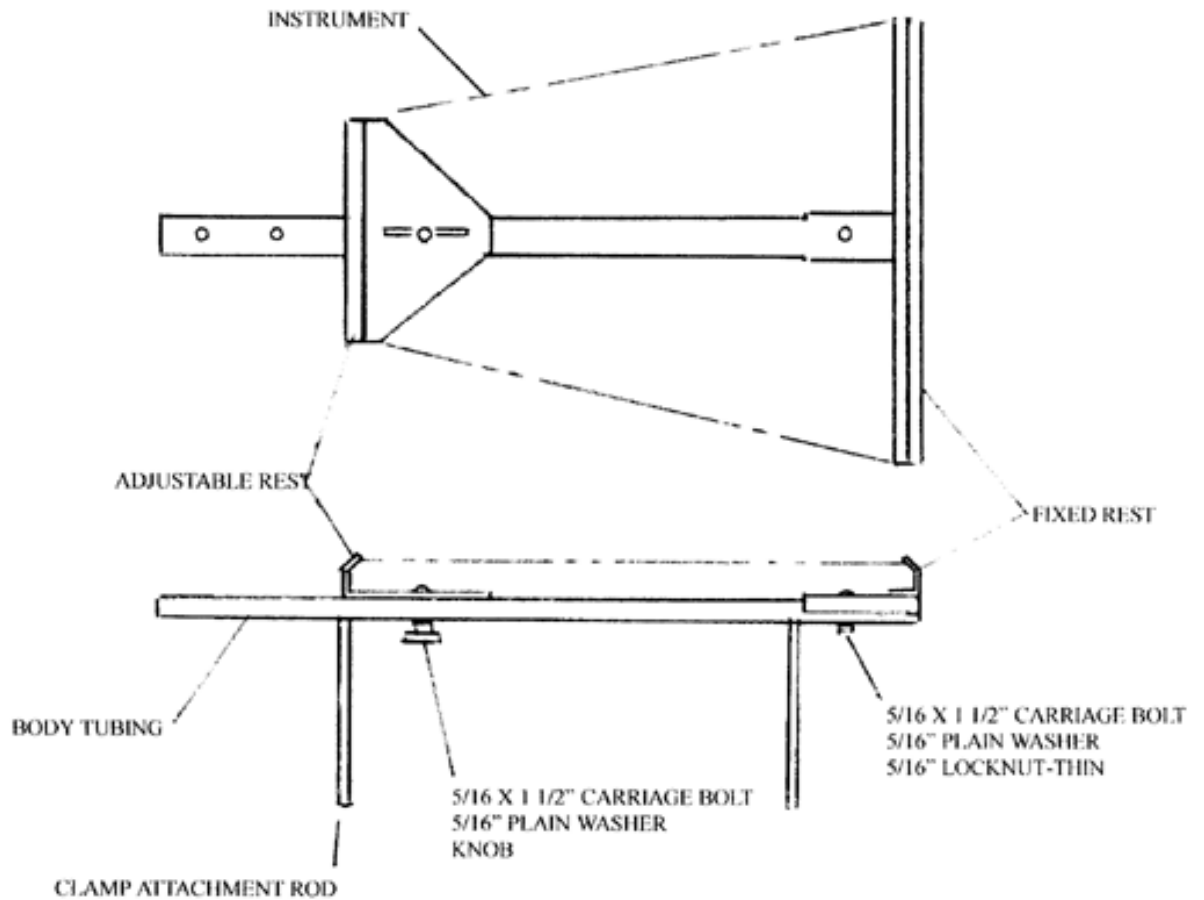

VIEW I