

SPEAKER ASSEMBLY INSTRUCTIONS

MOVIE

1. Assemble pan to main frame.
2. Assemble left & right frame angles to pan.
3. Assemble handle and channel to frame angles.
4. Assemble both braces to pan and angle.
5. Install one set screw collar on each axle, (You may need to drive collar on axle because of paint build up.) Tighten set screw.
6. Install one wheel on each axle.
7. Install one adjustment strap on each axle.
8. Install set screw collar on each axle. Leave approx. 1/16" gap, tighten set screw.

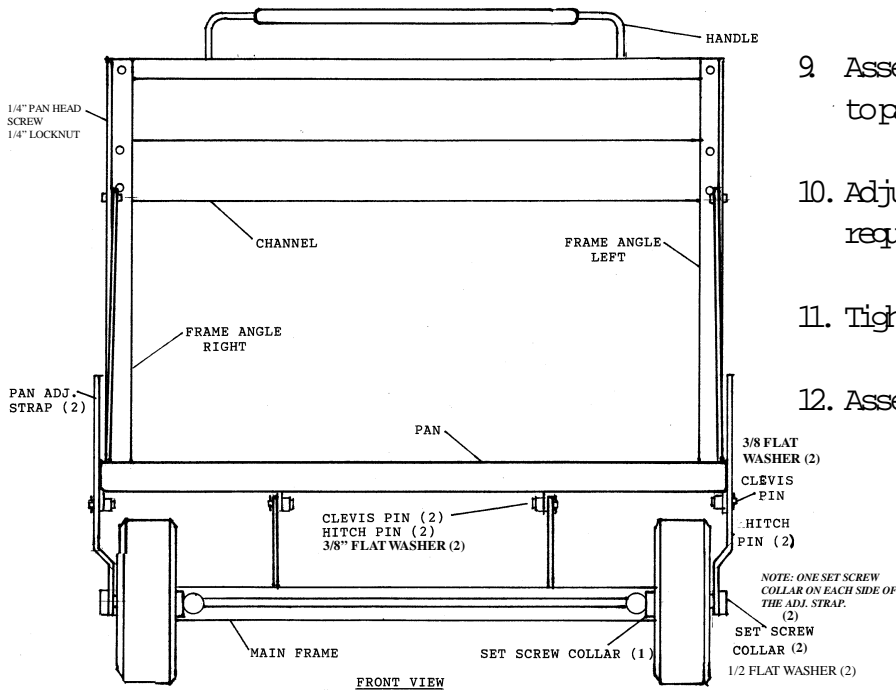
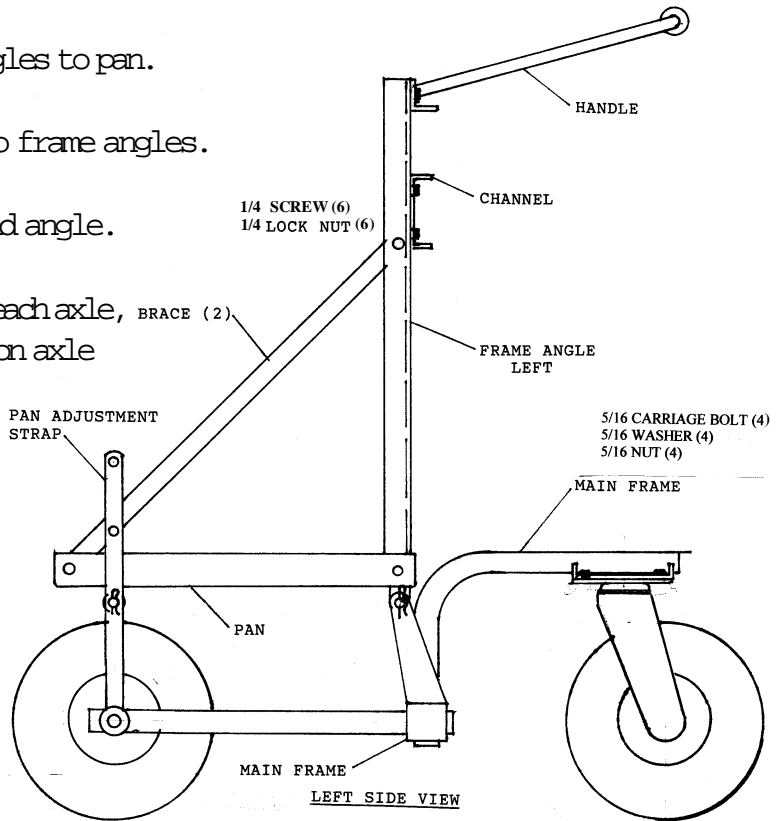

9. Assemble adjustment strap to pan.
10. Adjust angle of pan as required.
11. Tighten all fasteners securely.
12. Assembly is complete.